

MYERS® APLEX SERIES

MA-120M-HD

TRIPLEX PLUNGER PUMP

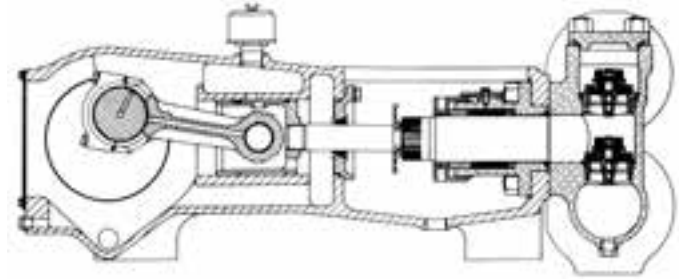

No. of plungers	3
Maximum rated speed	450 rpm
Stroke length.....	4.25 in. 108.0 mm
Maximum rated power.....	144 HP 104 KW
Maximum rod load	8937 lb. 39.8 kN
Weight	1950 lbs.

ENGLISH UNITS

MA-120M-HD

PLUNGER SIZE IN.	STUFFING BOX BORE IN.	MAX PSI.	*GALLON PER/ REV.	250 RPM US GPM	300 RPM US GPM	350 RPM US GPM	400 RPM US GPM	450 RPM US GPM
2.250	3.250	2250	0.219	54.9	65.8	76.8	87.8	98.8
2.125	3.250	2520	0.196	48.9	58.7	68.5	78.3	88.1
2.000	2.875	2850	0.173	43.4	52.0	60.7	69.4	78.0
1.875	2.875	3230	0.152	38.1	45.7	53.3	61.0	68.6
1.750	2.875	3715	0.133	33.2	39.8	46.5	53.1	59.7
1.625	2.875	3900	0.114	28.6	34.3	40.1	45.8	51.5

HP REQUIRED @ RPM**	80.1	96.1	112.1	128.1	144.1
---------------------	------	------	-------	-------	-------

METRIC UNITS

MA-120M-HD

PLUNGER SIZE MM.	STUFFING BOX BORE MM.	MAX PRESS. BAR	* LITER PER/REV.	250 RPM LPM	300 RPM LPM	350 RPM LPM	400 RPM LPM	450 RPM LPM
57.2	82.6	155.0	0.831	207.7	249.3	290.8	332.4	373.9
54.0	82.6	173.6	0.741	185.3	222.4	259.4	296.5	333.5
50.8	73.0	196.0	0.656	164.1	196.9	229.7	262.6	295.4
47.6	73.0	223.2	0.577	144.2	173.1	201.9	230.8	259.6
44.5	73.0	256.0	0.503	125.7	150.8	175.9	201.1	226.2
41.3	63.5	268.6	0.433	108.4	130.0	151.7	173.4	195.0
38.1	63.5	297.7	0.369	92.3	110.7	129.2	147.6	166.1

KW REQUIRED @ RPM**	59.4	70.2	83.2	95.1	107.3
---------------------	------	------	------	------	-------

*Displacement based on 100% Volumetric Efficiency

**Power based on 90% Mechanical Efficiency

$$IHP = \frac{USGPM \times (\text{Discharge psig} - 1/2 \text{ Suction psig})}{1542}$$

$$IKW = \frac{M^3/HR \times (\text{Discharge Bar} - 1/2 \text{ Suction Bar})}{17.99}$$

$$PUMP \text{ RPM} = \frac{USGPM \text{ Desired}}{USGPM \text{ per Revolution of Selected Plunger}}$$

$$PUMP \text{ RPM} = \frac{M^3/HR \text{ Desired}}{M^3 \text{ per Revolution of Selected Plunger}}$$

MA-120M-HD Triplex Pump

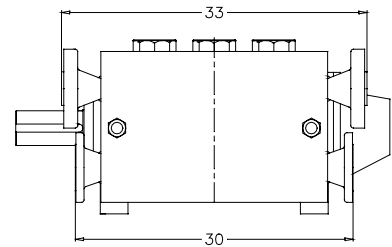
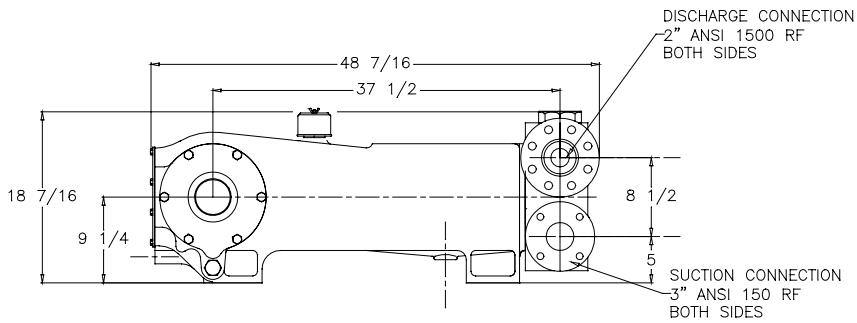
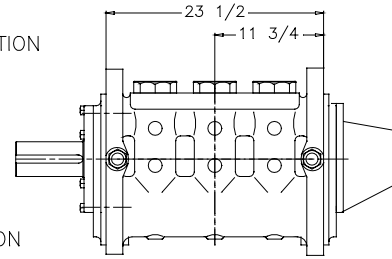
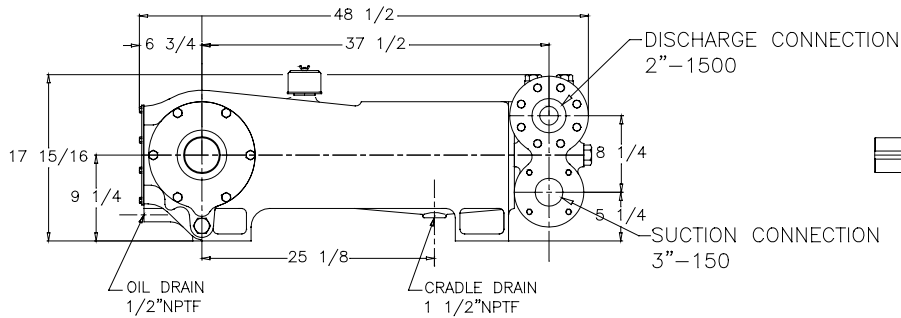
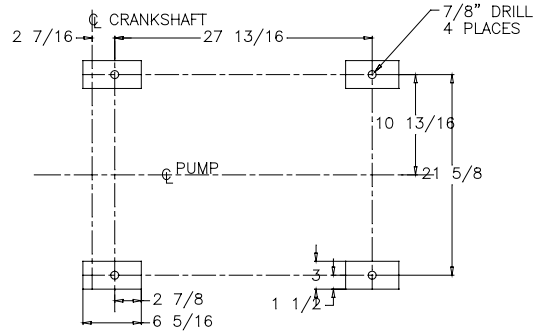
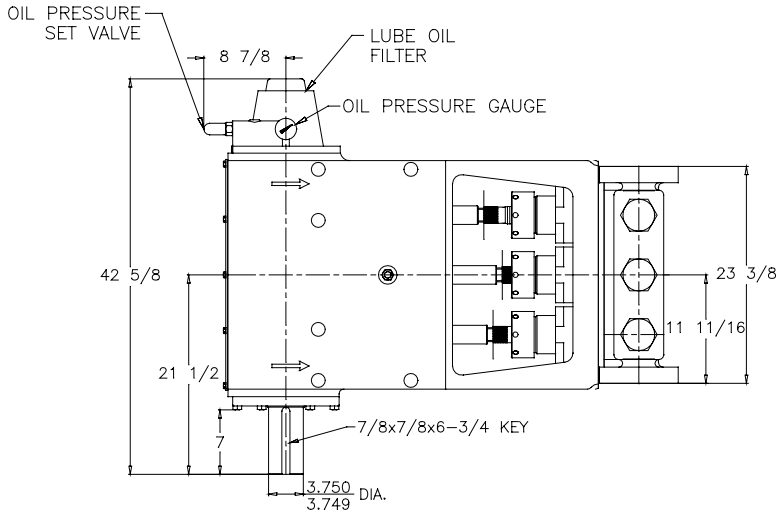

ENGINEERING DATA

MA-120M-HD Triplex Pump

POWER END ENGINEERING DATA

Max. Input HP @ Speed	144 @ 450 RPM
Rated Continuous Plunger Load	8937 lb.
Max. Rated Continuous Speed	450 RPM
Normal Continuous Speed Range	150 to 420 RPM
Minimum Speed	100 RPM
Oil Capacity	18 U.S. Qrts
Power End Oiling System	Splash & Scoop
Power Frame, One-Piece	Cast Iron
Crosshead, Full Cylindrical	Cast Iron
Crosshead, Dia. x Length	5 3/4 x 6 3/16 inches
Crankshaft	Ductile Iron
Crankshaft Diameters:	
At Tapered Roller Bearings	4 in.
At Crankpin Bearings, Dia. x Length	4 x 3 inches
Crosshead (Wrist) Pin, Case-Hardened and Ground	AISI 8620
Main Bearings, Tapered Roller	Timken®
Crankpin Bearings, Precision Automotive	Steel Backed, Babbitt-Lined
Extension (Pony) Rod, Integral w/ Plungers	316 S.S.
Connecting Rod, Automotive Type	Ductile Iron
Average Crosshead Speed @ 450 rpm	318 fpm
Minimum Life Expectancy, Main Bearings, L ₁₀	37,000+ hr.

LIQUID END ENGINEERING DATA

Max. Continuous Working Pressure	3,250 psi
Hydrostatic Test	4,875 psi
Available Liquid End Materials, A.S.T.M.	
Stainless Steel Block	Various Grades
Nickel Aluminum Bronze Casting	B148-C955
Forged Steel Block	A105
Plunger Type Rokide® (Chromium Oxide-Coated)	316 S.S.
Stuffing Boxes, Field-Removable and Replaceable	
Aluminum Bronze	B148-C955
Carbon Steel.....	1020
Packing Types Available	
Gland-loaded, Non-Adjustable	Style 838
Spring-loaded, Braided Teflon® & Kevlar®	Style 140
Spring-loaded, cup-type	Style 120X
Spring-loaded, Garlock	Style 892LK
Seals, Stuffing Boxes, Valve Covers, Cyl. Heads	Buna-N
Disc Valve Types	
Regularly furnished, acetal resin	Delrin®
Optional, hardened and lapped.....	17-4 PH S.S.
Valve Spring material	Inconel®
Valve Seat, Liquid Passage Areas	
Plate (disc) Valves, (Delrin or S.S.)	2.35 sq.in.
Avg. Liquid Velocity with 2 1/4" plunger @ 450 rpm	
thru Valves.....	8.97 fps
thru Suction Manifold	4.47 fps
thru Discharge Manifold	10.09 fps

All drawings and specifications subject to change without notice.

MA-120M-HD Triplex Pump

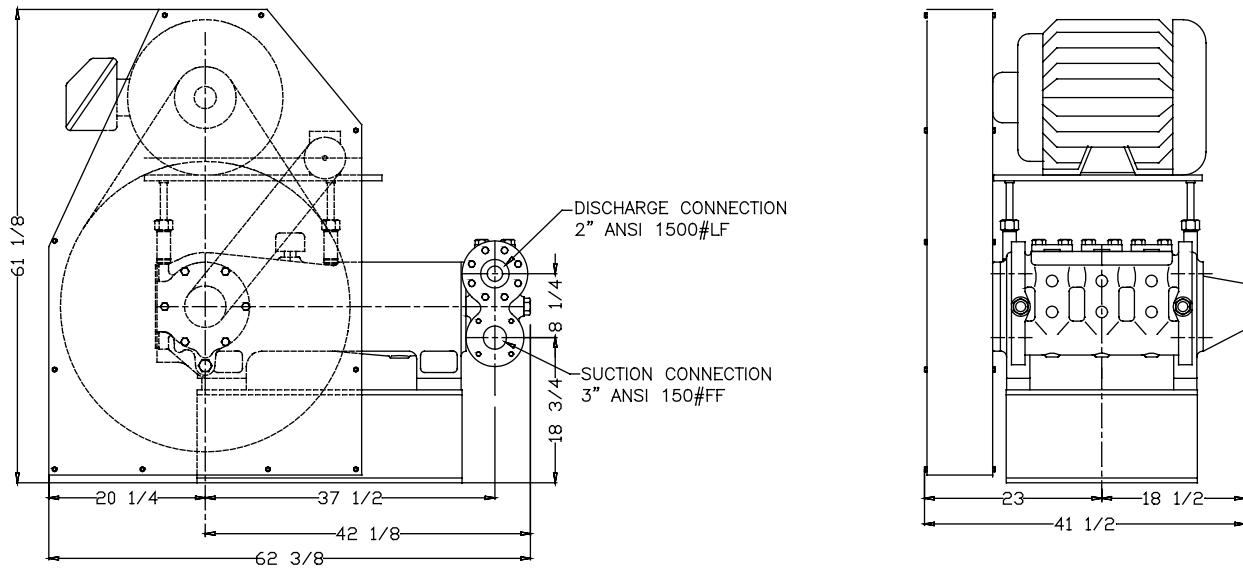

740 EAST 9TH STREET,
ASHLAND, OHIO 44805
WWW.FEMYERS.COM

490 PINEBUSH ROAD, UNIT 4,
CAMBRIDGE, ONTARIO N1T 0A5
WWW.FEMYERS.COM

Delrin®, Teflon® and Kevlar® are registered trademarks of E. I. du Pont de Nemours and Company.

Inconel® is a registered trademark of the Special Metals family of companies.

Timken® is a registered trademark of The Timken Company. Rokide® is a registered trademark of Saint-Gobain Abrasives, Inc.

Myers® is a registered trademark of Pentair.

Because we are continuously improving our products and services, Pentair reserves the right to change specifications without prior notice.

MA1021-HD 01/15/14 © 2014 Pentair Ltd. All Rights Reserved.

www.powerzone.com