



POWER ZONE
Equipment, Inc.

Official Distributor of Pentair Industrial Products

MYERS® APLEX SERIES

SC-65L

TRIPLEX PLUNGER PUMP

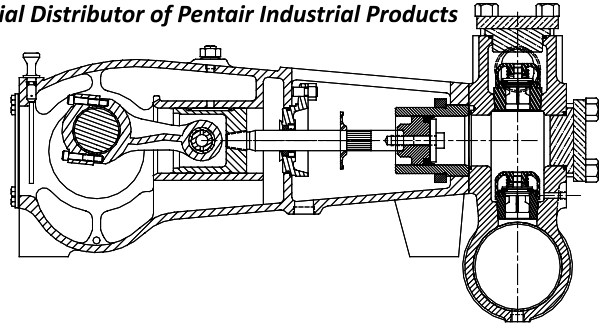

Intermittent Duty Only

No. of plungers.....	3
Maximum rated speed.....	550 rpm
Stroke length.....	2.75 in. 69.85 mm
Maximum rated power.....	92 HP 68.5 KW
Maximum rod load	7216 lb. 32.04 kN
Weight	750 lbs.

ENGLISH UNITS

SC-65L

PLUNGER SIZE IN.	STUFFING BOX BORE IN.	MAX PSI.	* GALLON PER/REV.	200 RPM US GPM	250 RPM US GPM	350 RPM US GPM	450 RPM US GPM	550 RPM US GPM
3.000	PISTON	1050	0.252	50.5	63.1	88.3	113.6	138.8
2.750	3.500	1215	0.212	42.4	53.0	74.2	95.5	116.7
2.625	3.500	1334	0.193	38.7	48.3	67.6	87.0	106.3
2.500	3.250	1471	0.175	35.1	43.8	61.4	78.9	96.4
2.375	3.250	1630	0.158	31.6	39.6	55.4	71.2	87.0
2.250	2.875	1815	0.142	28.4	35.5	49.7	63.9	78.1

HP REQUIRED @ RPM**

33.4	41.8	58.5	75.2	92.0
------	------	------	------	------

METRIC UNITS

SC-65L

PLUNGER SIZE MM.	STUFFING BOX BORE MM.	MAX PRESS. BAR.	* LITER PER/REV.	200 RPM LPM	250 RPM LPM	350 RPM LPM	450 RPM LPM	550 RPM LPM
76.2	PISTON	72.4	0.995	199.1	248.8	348.4	447.9	547.5
69.9	88.9	83.8	0.829	165.8	207.3	290.1	373.0	455.9
66.7	88.9	92.0	0.732	146.3	182.9	256.1	329.3	402.4
63.5	82.6	101.4	0.664	132.7	165.9	232.3	298.6	365.0
60.3	82.6	112.4	0.599	119.8	149.7	209.6	269.5	329.4
57.2	73.0	125.1	0.538	107.5	134.4	188.1	241.9	295.6

KW REQUIRED @ RPM**

24.9	31.1	43.6	56.1	68.6
------	------	------	------	------

*Displacement based on 100% Volumetric Efficiency

**Power based on 90% Mechanical Efficiency

$$IHP = \frac{USGPM \times (\text{Discharge psig} - 1/2 \text{ Suction psig})}{1542}$$

$$IKW = \frac{M^3/HR \times (\text{Discharge Bar} - 1/2 \text{ Suction Bar})}{17.99}$$

$$PUMP \text{ RPM} = \frac{USGPM \text{ Desired}}{USGPM \text{ per Revolution of Selected Plunger}}$$

$$PUMP \text{ RPM} = \frac{M^3/HR \text{ Desired}}{M^3 \text{ per Revolution of Selected Plunger}}$$

SC-65L Triplex Pump

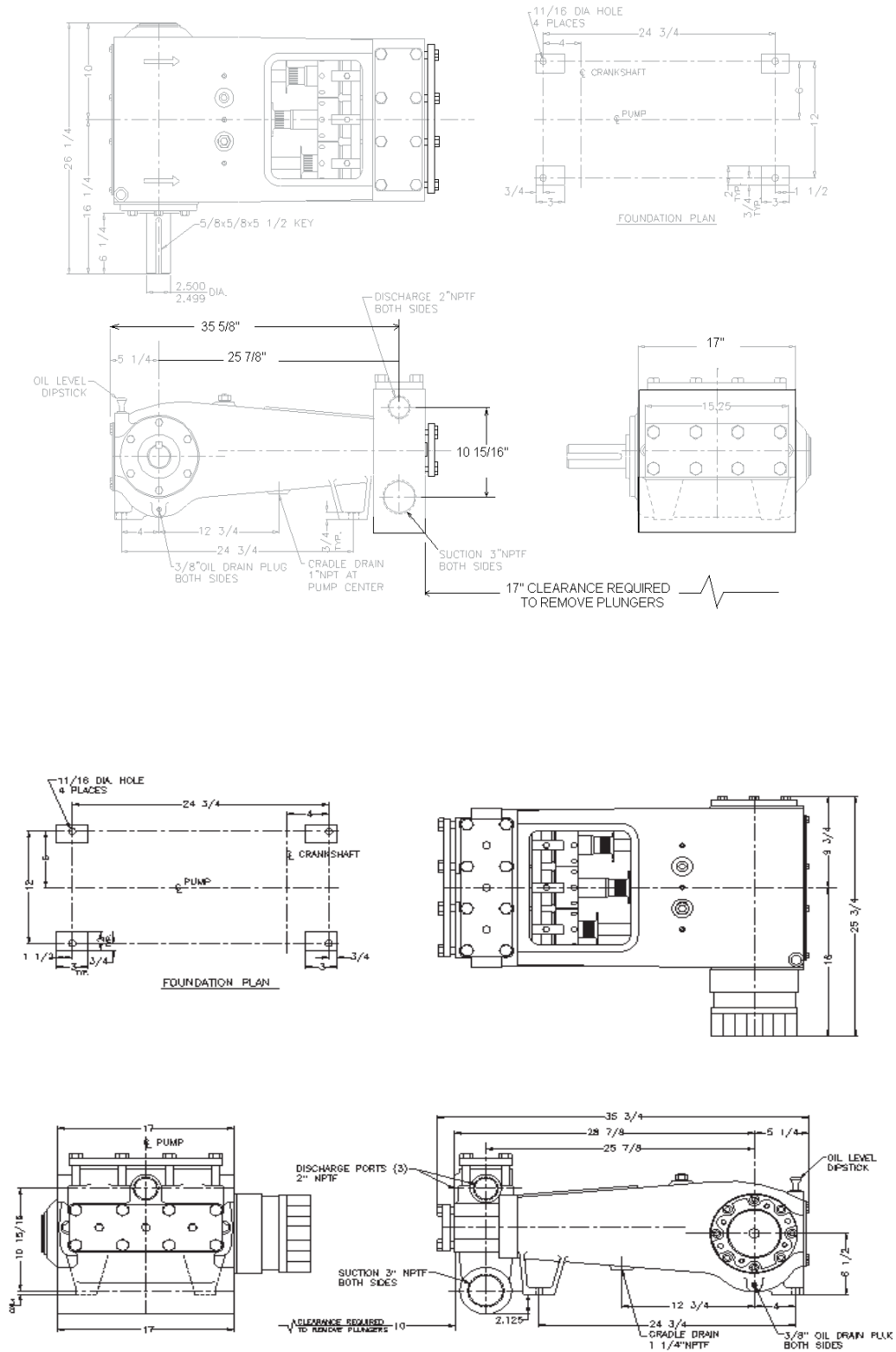

ENGINEERING DATA

SC-65L Triplex Pump

POWER END ENGINEERING DATA

Max. Input Power @ Speed	92 HP @ 550 rpm
Rated Continuous Plunger Load	7,216 lb.
Normal Continuous Speed Range	100 rpm
Minimum Speed	100 rpm
Oil Capacity	8 U.S. Qrts
Power End Oiling System	Splash & Scoop
Power Frame, One-Piece	Cast Iron
Crosshead, Full Cylindrical	Cast Iron
Crosshead, Dia. x Length.....	4 x 4 1/2 in.
Crankshaft	Ductile Iron
Crankshaft Diameters:	
At Tapered Roller Bearings	3.35 in.
At Crankpin Bearings, Dia. x Length.....	2 3/4 x 2 in.
Crosshead (Wrist) Pin, Case-Hardened and Ground	AISI 8620
Main Bearings, Tapered Roller	Timken®
Crankpin Bearings, Precision Automotive	Babbitt-Lined
Extension (Pony) Rod Integral w/ Plungers	316 S.ST.
Connecting Rod, Automotive Type	Ductile Iron
Average Crosshead Speed @ 550 rpm	252 fpm
Minimum Life Expectancy, Main Bearings, L ₁₀	30,000+ hr.

LIQUID END ENGINEERING DATA

Max. Continuous Working Pressure	1,815 psi
Hydrostatic Test	2,725 psi
Liquid End Materials, A.S.T.M.	
Ductile Iron	A536 80-55-06
Carbon Steel.....	A36
Stainless Steel	316 or 2205 S.ST.
Plunger Type “Rokide” Stainless Steel, (Chromium Oxide-Coated)	316 S.ST.
Stuffing boxes, Field-Removable and Replaceable, Carbon Steel	1020
Packing Types Available:	
Gland-loaded, Non-adjustable	Style 838
Spring-loaded, Braided Teflon & Kevlar	Style 140
Spring-loaded, cup-type	Style 120X
Spring-loaded, Garlock	Style 892IK
Valve Cover and Cyl. Head Plugs	316 S.ST.
Retainer Plates, Steel, A.S.T.M.	A36
Seals, Stuffing Boxes, Valve Covers	Buna-N
Valve Type, Double Stem-Guided	17-4PH S.ST.
Valve Spring Material	Inconel®
Valve Seat, Liquid Passage Area.....	2.23 sq.in.
Avg. Liquid Velocity, with 2 3/4” Plungers @ 550 RPM	
thru Plate Valves.....	7.3 fps
thru Dual Valves.....	12.3 fps
thru Suction Manifold.....	5.2 fps
thru Discharge Manifold.....	14.1 fps



740 EAST 9TH STREET,
ASHLAND, OHIO 44805
WWW.MYERSAPLEX.COM

269 TRILLIUM DRIVE, KITCHENER,
ONTARIO, CANADA N2G 4W5
WWW.MYERSAPLEX.COM

Inconel® is a registered trademark of the Special Metals family of companies
Timken® is a registered trademark of The Timken Company
Myers® is a registered trademark of Pentair Ltd.

Because we are continuously improving our products and services, Pentair reserves the right to change specifications without prior notice.
MA3006 03/11/13 © 2013 Pentair Ltd. All Rights Reserved.

www.powerzone.com